



America's Favorite Garage Doors®

VERTISTACK® AVANTE® GARAGE DOORS

CARE AND MAINTENANCE

This manual covers the following:

- ANNUAL MAINTENANCE
- CLEANING & PRESERVING THE DOOR
- FINISHING
- REPAIR AND REFINISH
- WARRANTY INFORMATION

MODEL _____

SIZE _____

S/N _____

PID # _____

Let us know what you think!

open camera and point



REVIEW YOUR DOOR

clopaydoor.com/leave-a-review

open camera and point

REGISTER YOUR DOOR

clopaydoor.com/warranty-registration



For any questions please contact VSCX team at VertiStack@Clipay.com
or at 800-526-4301, option 8.

MAINTENANCE

⚠ WARNING

Do not attempt to adjust door components. Maintenance can only be performed by a VertiStack® Certified Installer. IF THE DOOR IS NOT RUNNING SMOOTHLY AND/OR LEVEL OR IF YOU EXPERIENCE ANY ISSUES WHATSOEVER, IMMEDIATELY STOP USE OF THE DOOR AND CONTACT A VERTISTACK® CERTIFIED INSTALLER. Never attempt to adjust, maintain or repair any door component yourself. Doing so may cause door sections to release with force that may result in death or severe injury (such as pinch, crush or amputation-type injuries).

- Avoid touching the door at all times, but if necessary for cleaning or other non-operational reason, do so only when in the fully closed and locked position.
- Visually inspect the door monthly to identify worn or broken parts, or determine if the door is out of adjustment or unevenly balanced.
- Check all functionality of the door and operator, including smooth and level operation and all safety features.
- Every twelve (12) months, a VertiStack® Certified Installer must inspect the following for damage, loosening, and/or misalignment, and repair as necessary:
 - Door plumb/level
 - Straps
 - Torsion spring plugs and spring anchors
 - Bearings in end bearing plates
 - Rollers, rocker arms and slides
 - Track alignment
 - Bracket assembly attachment
 - Motor operator and hand crank
 - All screws and nuts – including set screws in bearings, spools, winding cones, etc.

INSPECTING WINDOW AND/OR ALUMINUM PANELS

⚠ WARNING

If glass or retainers appear to be or feel loose, warped, cracked, broken, shrunken or misshaped, immediately discontinue use of the door. Failure to do so may result in glass falling out of the panel causing property damage, serious injury or death. Contact your VertiStack® Certified Installer or the VSCX team at VertiStack@Clipay.com or at 800-526-4301, option 8.

We recommend that you inspect your window and/or aluminum panels every twelve (12) months at a minimum by doing each of the following:

Inspect the window and aluminum panels.

- With the door closed and locked, unplug from wall and disconnect the batteries from inside the control box.
- From inside and outside the garage, visually inspect all panels to ensure they are not loose, cracked or warped.
- From inside the garage, visually inspect the edge of each panel retainer for any shrinkage, loosening, cracking, warping or misshaping. Proper retainers should not show any gaps in the corner(s) of the window areas and should appear flat, straight and flush with the window/aluminum panel.
- Physically inspect the retainers by pressing the center of each retainer. You should feel little to no movement and not be able to compress the retainer more than 1/8".

DOOR OPERATION CHECKLIST

We recommend that at least twice per year after you have visually inspected the door and all of its components to:

- Make sure that the "photo eyes" and reflectors are securely mounted and aligned properly.
- Starting in the fully closed position, open and close the door, paying close attention to the smooth and level operation of the door. If you notice any uneven sections or any section that appears "stuck" (even for a short period of time), immediately stop use of the door and contact a VertiStack® Certified Installer.

LUBRICATE THE DOOR

At least twice per year, lubricate all moving parts of the door with Clopay® Garage Door Pro Lube or a synthetic lubricant:

- Rollers at the bearing (but not the tire)
- Full length of torsion spring to reduce friction between coils

CLEANING AND PRESERVING THE DOOR

Doors must be cleaned at least twice a year or four or more times a year for harsh environments (such as coastal regions, high road salts, etc.). If salt or other corrosive materials build up on the door and are visible, the door must be cleaned to avoid corrosion or other issues.

NOTICE *Failure to do so may result in loss of warranty coverage. For further questions about the requirements, contact Clopay Consumer Services.*

Proper cleaning helps prevent damage caused by foreign matter or salt adhering to the door and damaging the door's finish or affecting its operation, as well as helps restore the look of the factory-applied finish.

CLEANING THE DOOR

Starting with the door in the fully-closed and locked position, do each of the following:

- Check to make sure any debris in the magazine and/or magazine track of the door is removed to ensure the smooth transition of rollers from the magazine to the vertical track. See red areas (Fig. 1).
- Using a well-soaked cloth, sponge or soft bristle brush with a mild household solution (such as Dawn® dishwashing detergent), work from the top to the bottom of the door to remove any dirt or build-up. A fine scouring pad may be used for heavy surface soils, but only scrub with the direction of the metal grain and do not apply too much pressure.

NOTE: DO NOT use scouring powders or solvents with bleach or diluted bleach as an acidic cleaner. Avoid cleaning in the hot sun.

- Rinse door with clean water to complete cleaning and allow to dry.

NOTE: Be sure to clean behind top and bottom seals. Refer to "Window Care" for detail on window cleaning on the next page. **DO NOT** use a pressure washer on the door.

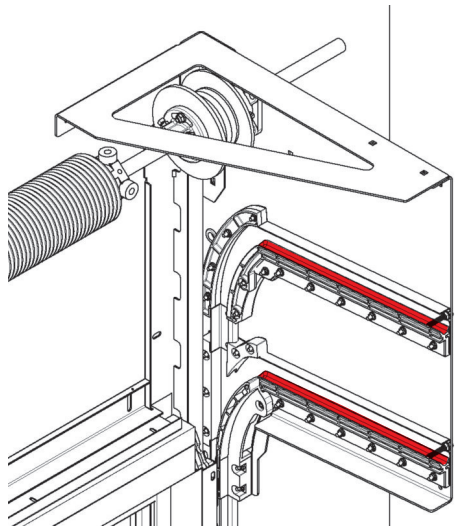

Fig. 1

REPAIRING OR PAINTING THE DOOR

Surface damage can be easily repaired provided the damage is slight; such as a small scratch or rub mark.

REPAIRING OR PAINTING – ANODIZED ALUMINUM FINISH DOOR

Rub marks can be removed with a mild abrasive pad, such as the Scotch-Brite™ pad prior to touch-up painting.

NOTE: DO NOT sand the anodized material when touching up.

- Clean the area to be touched up with denatured alcohol to remove moisture.
- Apply the provided touch-up paint very sparingly as this is intended for small blemishes less than a few square inches.

NOTE: For more severe damage or repainting, we recommend contacting a professional who specializes in the refinishing of architectural metals.

REPAIRING OR PAINTING – PAINTED ALUMINUM FINISH DOOR

- Minor damage to the painted surface should be sanded prior to application of the touch-up paint.
- Clean the area to be touched up with denatured alcohol to remove moisture.
- Apply the provided touch-up paint very sparingly, as this is intended for small blemishes less than a few square inches.

NOTE: For more severe damage or repainting, we recommend contacting a professional who specializes in the refinishing of architectural metals.

WINDOW CARE

- Clean with a mild solution of a dishwashing detergent and a soft cloth.

NOTE: DO NOT use any ammoniated, abrasive or solvent-based cleaners of any kind.

NOTE: For acrylic or polycarbonate windows: These windows **CAN ONLY** be washed using a clean, soft sponge or cloth with a mild dish soap and lukewarm water. Dry with soft cloth or chamois to prevent spotting. **DO NOT** brush, scrub or scrape these windows.

- After cleaning, rinse thoroughly.

NOTICE Use care when handling decorative windows to avoid scraping or scratching the surface.

GLASS REPLACEMENT

WARNING

DO NOT try to replace the glass yourself. Doing so may result in glass falling out of the panel causing property damage, serious injury or death.

If glass should need replacement, contact a VertiStack® Certified Installer.

LIMITED WARRANTY

RESIDENTIAL VERTISTACK® DOOR SYSTEM

Subject to the terms of this Limited Warranty ("Warranty") and any warranty policies and procedures in effect at the time a notice of a claim is received by Clopay Corporation (collectively, "Clopay", "we", or "our"), we will repair or replace – at our sole discretion – any door components, hardware, springs/spring components, or electrical components (collectively, "Parts") of your Residential VertiStack® Door System (the "Product") that we confirm through persons authorized by Clopay to be defective in material or workmanship, so long as timely written notice is provided within the applicable Warranty periods provided below. This Warranty shall apply to and benefit only the original purchaser and is nontransferable.

To maintain and not void this Warranty, and to ensure proper operation of the Product, each of the following must be strictly followed:

- The Product must be installed, handled, and maintained/repaired by a Clopay-approved dealer who has completed all manufacturer-required training ("VertiStack Installer") and strictly in accordance with the Product's Installation Manual.
- The Product is NOT to be touched at anytime with the exception of cleaning the Doors when in the fully-closed and locked position. Using, touching or handling the Product except as provided in the Product's Installation Manual or Care and Maintenance Manual will be considered improper use or misuse of the Product.
- **If the Product becomes stuck or does not operate as intended for any reason, you must immediately stop use of the Door and contact a VertiStack Installer for service. DO NOT TOUCH THE DOOR OR ATTEMPT REPAIR. Failure to follow these instructions will be considered improper use or misuse of the Product.**
- The Product must be operated at all times using only the motor provided. Although each Product comes with a hand crank kit that engages with the motor to raise and lower the door, this hand-crank is for emergency use only. Frequent and/or excessive use of the hand-crank will be considered improper use or misuse of the Product.
- The Product must be maintained solely by a VertiStack Installer at maintenance interval(s) required in the Product manual, including – but not limited to – annual testing and maintenance and acceptance testing. All Product repairs must be performed by an approved VertiStack Installer. All replacement Parts used must be supplied directly by Clopay. Proof of purchase and service records reflecting maintenance and/or repairs must be retained and produced upon request.
- All warnings, installation and operational guidelines must be strictly followed to help ensure safe Product operation and installation. UL or FM-listed and labeled doors that are installed outside of the abstract of the listing and specific dimensions can result in catastrophic failure and void this Warranty.
- The Product is designed to be water-resistant, but is not waterproof. Water infiltration may occur in the event that the Product is exposed to prolonged and/or substantial rainfall or water sources. Due to inconsistencies in building construction and finishing work, light penetration around and between Product sections is not considered a manufacturing defect of the Product.
- The Product shall not be operated when external temperatures are below -15°F/-26°C, which may cause damage to the door and void this Warranty.
- The Product is designed and intended for use in residential garage, workshop and barn applications, and not to be used as a primary or sole point of ingress/egress under any circumstances. Use of the Product in other applications may be considered improper use or misuse and void this Warranty.
- Incoming line voltages must fall within ranges established by ANSI C84.1 (ANSI Standard for Electrical Power Systems and Equipment) and wiring must be connected in accordance with applicable standards established by the current edition of NFPA-70 (NEC) for residential door operators.

PRODUCT OR PART	MATERIAL & WORKMANSHIP	POWDERCOAT FINISH (COMPONENTS ONLY)	ELECTRICAL COMPONENTS	INSULATED GLASS
Residential VertiStack® Door System	2 Years (Prorated for standard wear items)	2 Years*	2 Years Applicable Manufacturer's Warranty**	5 Years

* RAL powder coat finish on brackets, covers, and other steel components are warranted against fading, cracking, blistering, flaking or peeling

** At Clopay's election, certain electrical component(s) shall be subject solely and exclusively to the terms, exclusions, and time periods of the manufacturer of such electrical component(s). Such terms, exclusions and time periods may be different than this Warranty. These warranties are available upon request.

EXCLUSIONS TO COVERAGE

This Warranty specifically excludes the situations listed in the below "Exclusions to Coverage" and shall not extend to damages or defects caused by any of the following:

Failure to yearly use an approved VertiStack Installer for Installation, Repairs and/or Maintenance	Failure to Follow All Maintenance Instructions	Failure to Provide Proof of Maintenance Documentation with Claim	Light infiltration around and between Residential VertiStack® door sections
Salt Spray or Exposure to Coastal Weather Conditions	Fire	Radiation (UV or Other)	Foreign Substances
Accident or Casualty	Harmful Fumes	Vandalism	Act(s) of God
Physical Damage	Faulty or Defective Installation(s)	Normal Wear and Tear	Chemical Action
Abrasive Materials	Operation Beyond Rated Capacity	Improper Use, Misuse, or Abuse	Improper Installation or Handling
Line Voltage Fluctuations	Overloads, Transformers, and Logic Boards	Line Voltages Outside Ranges Established by ANSI C84.1	Wiring not Connected in Accordance with Applicable Standards in Current Edition of NFPA-70 (NEC).
Alteration or Modification to the Product or Use of Non-Approved Third-Party Parts or Products	Operating the Residential VertiStack® door in temperatures below -15°F/-26°C	Improper Use or Overuse of the Hand Crank	Overloads, transformers, and logic boards are not subject to this Warranty as these items are subject to improper field wiring and or line voltage fluctuations.
Improper cleaning and/or agents*		Water infiltration from exposure to prolonged and/or substantial rainfall or water sources	

* For a list of approved cleaning methods and agents, visit info.garagedoors.com/maintenance.

LIMITED WARRANTY

RESIDENTIAL VERTISTACK® DOOR SYSTEM, CONT'D

This Warranty specifically excludes any and all additional or consequential costs for materials, labor, or damages that may be required due to project schedule (including – but not limited to – delay damages, etc.), site conditions, adjacent construction or other installation activities, incorrect installation, lack of maintenance, lack of access, equipment or rental costs, damage(s) to adjacent construction, structures or areas, security requirements (e.g., security guards, temporary doors, blockades, and the like), or any other cost outside of those explicitly covered by this Warranty.

REPLACEMENT MATERIAL

Replacement Warranty material will be shipped via standard ground transportation. Expedited delivery charges will not be the responsibility of Clopay.

REPLACEMENT PARTS

All replacement Parts will be warranted for ninety (90) days from the date of shipment.

WARRANTY SUPPORT

For assistance with Warranty issues, please contact our VSCX team at VertiStack@Clopay.com or at 800-526-4301, option 8.

ADDITIONAL INFORMATION

UNDER NO CIRCUMSTANCES SHALL WE BE LIABLE FOR ANY CONSEQUENTIAL OR SPECIAL DAMAGES WHICH ANY PERSON OR ENTITY MAY INCUR OR CLAIM TO INCUR AS A RESULT OF ANY DEFECT IN THE PRODUCT OR IN ANY CORRECTION OR ALTERATION THEREOF MADE OR FURNISHED BY US OR OTHERS. OUR MAXIMUM LIABILITY UNDER THIS WARRANTY SHALL BE THE PURCHASE PRICE PAID TO US WITH RESPECT TO THE PRODUCT AND/OR PART TO WHICH SUCH WARRANTY IS CLAIMED, WHICHEVER IS LESS. THE LIMITATION OF LIABILITY PROVISIONS HEREIN SHALL APPLY TO ANY AND ALL CLAIMS OR SUITS BROUGHT AGAINST US, INCLUDING ANY CLAIM BASED UPON NEGLIGENCE, BREACH OF CONTRACT, BREACH OF WARRANTY, STRICT LIABILITY OR ANY OTHER THEORIES UPON WHICH LIABILITY MAY BE ASSERTED AGAINST CLOPAY.

This Warranty constitutes our entire and exclusive warranty as to the Product and is the sole and exclusive remedy for Product and/or Part defects in material and workmanship. We do not assume (and have not authorized any other person to assume on its behalf) any other warranty or liability in connection with any product covered by this Warranty. WE MAKE NO OTHER WARRANTIES, REPRESENTATIONS OR COVENANTS, EXPRESS OR IMPLIED, WITH RESPECT TO THIS PRODUCT AND/OR PART(S), INCLUDING BUT NOT LIMITED TO WARRANTIES, REPRESENTATIONS OR COVENANTS AS TO WORKMANSHIP, DESIGN, CAPACITY, QUALITY, CONDITION, MERCHANTABILITY OR FITNESS FOR ANY PARTICULAR PURPOSE, EXCEPT FOR ANY "IMPLIED WARRANTY" AS THAT TERM IS DEFINED IN THE MAGNUSON-MOSS WARRANTY-FEDERAL TRADE COMMISSION IMPROVEMENT ACT, WITH SUCH IMPLIED WARRANTIES TO BE LIMITED IN DURATION TO A PERIOD OF ONE (1) YEAR FROM THE DATE OF SHIPMENT.

This Warranty gives you specific legal rights, and you may also have other rights that vary from state to state.

To the extent of any conflict between this Warranty and any other document, this Warranty shall control. If Warranty is provided in multiple languages, the English language version governs.



© 2024 Clopay Corporation. All rights reserved.

DOOR INSTALLED ON DATE:

INSTALLED BY:

CONTACT YOUR CLOPAY DEALER FOR YOUR ANNUAL MAINTENANCE CHECK ON:

DOOR INSPECTION AND MAINTENANCE CHECKLIST:

	Years									
	1	2	3	4	5	6	7	8	9	10
Cleaned door.										
Visual inspection of door components.										
Lubricated all moving parts of the door.										

www.clopaydoor.com • 1-800-2CLOPAY (225-6729)

Patents can be viewed at <https://www.clopaydoor.com/patents-trademarks>

